

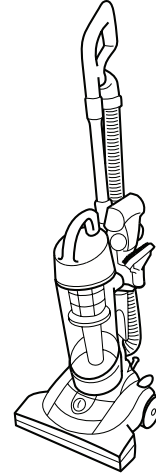

morphy richards®



Bagless upright vacuum cleaner

 Please read and keep these instructions

Getting the best from your new cleaner...

If your cleaner is not picking up as well as it should, please check

Dust canister

It is important to regularly empty the canister, even if it does not appear full.

Filters

It is important that the dust canister pleated/mesh filter is tapped clean over a dustbin each time the dust canister is emptied, this allows air through the appliance. Wash the canister filters regularly in luke-warm water and allow to air dry before re-fitting.

Blockages

Check the hose, tubes and tools for blockages.

Safety cut-out

If the air-flow is blocked or the filters are not regularly cleaned, a thermostat may operate. If this happens, switch off and disconnect from the mains supply. Clear any blockage, empty and clean the filters. Allow 60 minutes for the thermostat to reset.

Belt

If the brush-bar is not rotating, check the belt (as described on page 6). Replace any damaged or broken belts.



For replacement parts, help with using your Morphy Richards, problems and lots more, contact us by phone or through our website.

VC73281 MUK Rev 1



UK Helpline: 0844 871 0949
Replacement Parts: 0844 873 0715
Ireland Helpline: 1800 409 119

www.morphyrichards.com

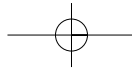

IMPORTANT SAFETY INSTRUCTIONS

The use of any electrical appliance requires the following common sense safety rules.

Please read these instructions carefully before using the product.

Primarily there is danger of injury or death and secondly the danger of damage to the appliance.

Location

- Do not use or keep this product outside.
- Do not store the appliance near hot surfaces eg. ovens or heating appliances.

Mains lead

- Do not allow the mains lead to become strained or run this appliance over it.
- If the electrical cable becomes damaged, the cable assembly must be replaced. Do not attempt this task yourself, contact the helpline number that is found at the bottom of the page.

Personal safety

- **WARNING: Keep loose clothing, hair, fingers etc. away from the floor nozzle whenever the cleaner is connected to the mains.**
- **WARNING: Only lift the product by the handle ①.**
- **Disconnect from the mains supply before attempting to clear blockages, clear the brush or replace the belt.**
- Disconnect from the mains supply before cleaning or emptying the appliance.

- Never modify the cleaner in any way.
- Never use in the presence of explosive liquid or vapours.
- Never pick up inflammable or poisonous liquids such as petrol, copier toner or other volatile substances. Never pick up acids, asbestos or asbestos dust.
- Never touch the plug or cable with wet hands.
- Unprofessional repairs can be dangerous for users.
- Use only Morphy Richards spare parts and accessories.
- The appliance must never be left running unsupervised.
- This appliance is intended for domestic use only. Misuse or use for commercial or any other purpose will render the guarantee invalid.
- Always disconnect the appliance from the mains supply after use.
- This appliance is not intended for use by persons (including children) with reduced physical, sensory or mental capabilities, or lack of experience and knowledge, unless they have been given supervision or instruction concerning use of the appliance by a person responsible for their safety.
- To protect against fire, electric shock and personal injury, do not immerse cord, plug or cleaner in water or other liquid.
- Never over-extend the hose such that the cleaner is pulled over. If the cleaner is knocked over, switch off before attempting to upright.
- Never pick the cleaner up by the floor nozzle when connected to the mains, use the carrying handle.

Children

- Children do not understand the dangers associated with operating electrical appliances. Never allow children to use this appliance.
- Children should be supervised to ensure that they do not play with the appliance, or stumble over the power cord.

Electrical requirements

Check that the voltage on the rating plate of your appliance corresponds with your house electricity supply which must be A.C. (Alternating current).

If the socket outlets in your home are not suitable for the plug supplied with this appliance, the plug should be removed and the appropriate one fitted.

WARNING: The plug removed from the mains lead, if severed, must be destroyed, as a plug with a bared flexible cord is hazardous if engaged into a live socket outlet.

Should the fuse in the 13 amp plug require changing, a 13 amp BS1362 fuse must be fitted.

Product safety

- Never use the appliance without the filters being installed.
- Never use the appliance to vacuum hot ashes, broken glass, sharp objects or liquids.

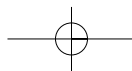

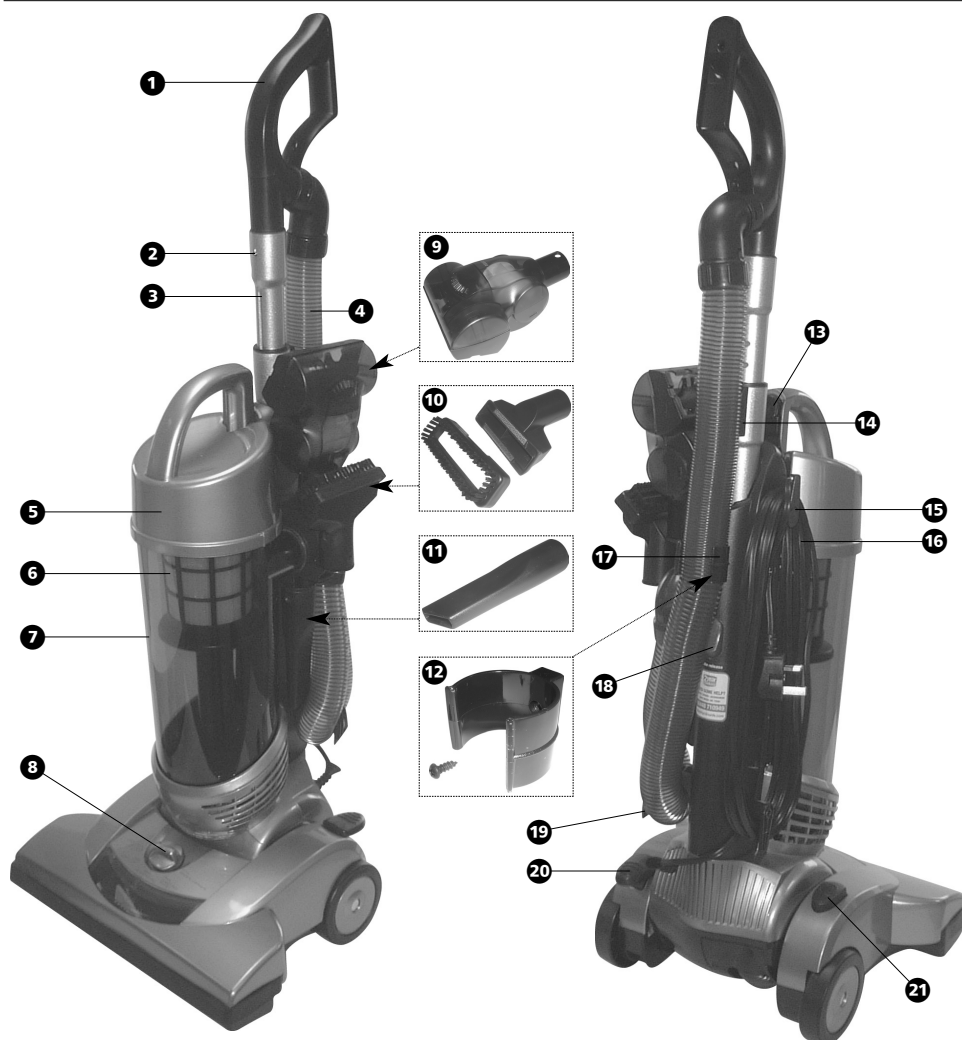

FEATURES

- | | | |
|---------------------------------------|---|-----------------------------------|
| 1 Handle | 9 Turbo tool (certain models only) | 15 Cord storage cleats |
| 2 Handle locking pin | 10 Upholstery tool / dusting brush | 16 Power cord |
| 3 Metal telescopic tube | 11 Crevice tool | 17 Hose clip (assembled) |
| 4 Stretch hose | 12 Hose clip (unassembled), including hose clip screw | 18 Telescopic tube release button |
| 5 Dust canister lid | 13 Dust canister release button | 19 Hose hook |
| 6 Filter assembly | 14 Handle height adjuster button | 20 Upright release pedal |
| 7 Dust canister | | 21 ON/OFF button |
| 8 Floor nozzle height adjustment dial | | |

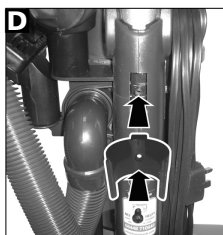
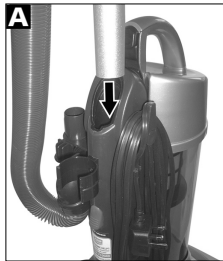

OPERATING THE APPLIANCE

Assembly

WARNING: Do not plug in the cleaner until it is assembled.

- 1 Carefully unpack all of the components.
- 2 Lift the cleaner body to the upright position.
- 3 Slide the telescopic tube (3) into the opening on the top of the unit. Ensure the telescopic tube fits in correctly, and is locked into place (A).
 - To remove the telescopic tube, press the release button (18), located on the rear of the vacuum cleaner, then lift the telescopic tube up (B).
- 4 Slide the handle (1) into the top of the telescopic tube. Ensure the handle locking pin (2) fits in place (C).
 - Remove the handle by pressing the locking pin, then pulling the handle up.
- 5 To increase the height of the handle, push downward on the handle height adjuster button (14) and raise the handle to the desired height. With the handle at the desired height, release the button, the handle will click securely into place.

Hose clip fitting (D)

- 1 Using a cross-head screwdriver, remove the hose clip screw from the rear of the product.
- 2 Insert the hose clip (12) into it's slot in the rear of the appliance.

- 3 Re-fit the screw and tighten. Do not overtighten.

Hose

Locate the hose under the hook and into the hose clip.

WARNING: Do not overstretch the hose, otherwise there is a risk of the product being pulled over.

Cord Storage

This appliance features convenient cord storage. Wind the power cord (16) around the two cord holder cleats (15) on the side of the unit. Turn the upper cord cleat to the left or right to quickly release the power cord.

USING

Unwind the power cord fully. Plug the cord into the supply mains. Press the ON/OFF button (2) to turn the vacuum cleaner on and off.

Release the handle by pushing the upright release pedal (20). This allows repositioning of the handle for storage, normal operation or cleaning beneath furniture (E).

Floor nozzle height adjustment

Before using the cleaner, the floor nozzle height must be set to the correct height.

Choose the setting which most closely matches your carpet height, using the floor nozzle height adjustment dial (3). This raises and lowers the brushbar to suit your carpet type.

When the cleaner is in it's upright position, or when using the hose (4) and tools (9, 10, 11), ensure the floor nozzle height adjustment dial is at the tools setting.

Using on carpets

- 1 Place the cleaner in its upright position.
- 2 Set the carpet height adjustment dial **8** to the desired position.
- 3 Release the mains cable by revolving the quick release cleat half-a-turn and extend the cable fully.
- 4 Plug the cable into the mains socket.
- 5 Step on the handle release pedal to release the handle to the desired position.
- 6 Press the ON/OFF button to the 'ON' position.

IMPORTANT: To prevent damage to carpets:

- Never leave the cleaner switched on in one place for an extended period.
- Never have the brushes set too low such that the cleaner is hard to push.
- Never lean on the product.

Using the attachments

Follow steps 1-4 of the 'Using on carpets' section, but set the carpet height adjustment dial to the tools setting.

- 5 Attach the accessories **9** **10** **11** to the handle, removing the handle from the telescopic tube, then firmly push in the desired accessory **F**.

Turbo tool 9 is ideal for pet hair removal from stairs and upholstery.

Upholstery tool 10 for upholstery, stairs etc.

Dusting brush 10 for delicate surfaces.

Crevice tool 11 for awkward places, corners and behind radiators etc.

- 6 If additional length is required, remove the telescopic tube from the cleaner, connect it to the handle, and add the desired accessory to the end of the tube **G**.

- 7 Switch ON/OFF.

- **IMPORTANT:** When using the hose and tools, locate the hose into the hose hook **19** on the main unit. This will help prevent the cleaner from tipping over.
- **IMPORTANT:** Turning the cleaner sideways helps prevent the cleaner being pulled along by the stretched hose.



Using & cleaning the turbo nozzle

Attach the Turbo nozzle to either the handle or the telescopic tube as described previously.

Following use, your turbo nozzle may become clogged. Switch the cleaner to 'OFF'. Turn over the tool and pull away any hairs or fibres. If they are tightly wound around the brush, carefully snip the fibres with scissors, being careful not to damage the brush bar, pull away from the brush bar and dispose.

SAFETY CUT-OUT

If the cleaner overheats, a motor protection thermostat will automatically switch the motor off. If this happens, **switch the cleaner off, unplug from the power supply and leave the cleaner to cool for at least 60 minutes.** Check the airways for blockages, empty the dust canister and clean the filters before restarting.



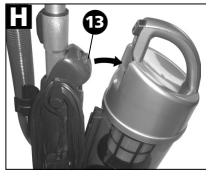

EMPTYING THE DUST CANISTER

Empty the dust canister (7) regularly even if it does not look full, this will maintain the performance.

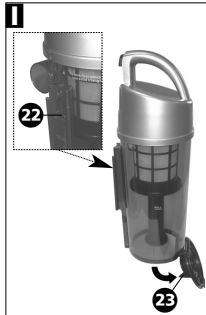

- 1 Unplug the cleaner from the mains switch.
- 2 Press the dust canister release button (15) and pull the canister away from the main body (H).
- 3 Take the canister to a dustbin.
- 4 Hold the dust canister over the dustbin. Press the empty release button (2) on the back of the canister. This opens the door (23) at the base of the canister for the contents to be emptied-out (I).



REMOVING AND CLEANING THE FILTERS

HEPA filter

IMPORTANT: After every empty, clean the dust canister filter (6).

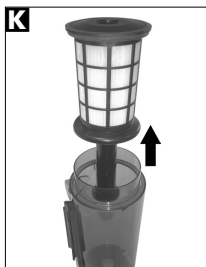

- 1 Empty the dust canister.
- 2 Remove the dust canister lid (5) by turning it counter-clockwise, then lifting off (J).
- 3 Lift the filter assembly out of the dust canister (K).
- 4 Lift out the mesh filter from the filter frame by twisting it counter-clockwise (L).

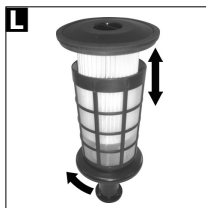

- 5 Tap the filter over a dustbin until no more dust falls out (M).
- 6 You may also wash the filter in luke-warm water, do not use detergents. It is recommended to wash the filter once a month or when suction seems reduced. Leave the filter to thoroughly air dry before refitting into the vacuum.



NOTE: The white material in the filter will become discoloured over time, this is normal and will not affect the filter's performance.

IMPORTANT: Always empty the dust canister and clean the filter and mesh following prolonged use. Never overfill the dust canister. Clean the filter and mesh screen every time the dust canister is emptied.

Motor protection filter

The motor protection filter (24) is located underneath the dust canister in the air-inlet pipe.

- 1 Remove the dust canister.
- 2 Lift out the filter (N) and shake over a dustbin.

The filter may also be washed in water (no detergents). Allow the filter to air dry. Ensure the filter is thoroughly dry before refitting.

- 3 Replace the filter.

Exhaust filter

The exhaust filter (25) is located below the dust canister compartment.

- 1 Remove the dust canister.
- 2 Remove the exhaust filter by twisting the motor protection filter cover (26) and lifting it away (O).
- 3 Lift the filter out and shake vigorously over a dustbin. The filter may also be washed in luke warm water. Do not use detergents. The filter must be completely dry before re-fitting. Allow filters to air dry naturally.
- 4 Replace the filter and the dust canister.

CHANGING THE BELT

If the brush bar (27) stops rotating, it is likely that the drive belt (28) has snapped (usually because the brush has been stalled). Replace the belt with the spare belt provided. Additional belts can be obtained from Morphy Richards by calling the helpline number at the base of the page.

■ Accessing the floor nozzle

- 1 Disconnect the cleaner from the mains supply.
- 2 Press the handle release pedal and place the cleaner face down on a soft surface, eg. carpet.
- 3 Remove the four screws holding the two undercarriage plates **29** in position. Remove the plates **P**.
- 4 Lift up the undercarriage **30** and unclip from it's location **Q**.
- 5 Underneath the undercarriage is the height adjustment cam. In the centre of the cam is a screw, remove this screw **R**.
- 6 Next, remove the four remaining floor nozzle screws **31**, two located by the rear wheels and two halfway along the floor nozzle **S**.
- 7 Turn the product over and pull off the height adjustment knob.
- 8 Lift the rear of the floor nozzle cover and unclip from the front. Put safely to one side **T**.

■ Removing and re-fitting the rotating brush bar & belt

- 1 Lift out the belt cover **32** **U**.
- 2 Gently lever out the right hand side of the brush-bar, followed by the left hand side **V**.
- 3 To re-fit, thread the brush-bar through the belt. Place the left hand side of the brush-bar into location, then place the belt around the motor shaft. Pull the brush-bar forwards (stretching the belt) and locate the right hand side of the brush-bar.
- 4 **IMPORTANT:** Make sure both ends of the brush-bar are fully and correctly located, and the belt is not trapped. The brush-bar should be able to be rotated by hand.
- 5 Re-fit the belt cover carefully, noting it's location.

■ Refitting the floor nozzle cover

- 1 Hook the front of the cover into the floor nozzle, then lower the rear of the cover. Note: it may be necessary to lift the upright portion of the product to allow the cover to fully close.
- 2 Refit the four main screws.
- 3 Turn the product over and check that the front of the cover is fully closed.
- 4 Insert the height adjustment knob, carefully turning it until it locates into the mating keyway on the cam.
- 5 Turn the product back over and locate the screw into the centre of the cam and tighten.
- 6 Clip the undercarriage into location and close into position.
- 7 Re-fit the two undercarriage plates and tighten the four screws.

Return the cleaner to the upright position. Connect to the mains supply and switch on to test.

■ HELPLINE

If you have any difficulty with your appliance, do not hesitate to call us.

We are more likely to be able to help than the store from where you bought it.

Please have the following information ready to enable our staff to deal with your query quickly.

- Name of the product
- Model number as shown on the rear of the appliance.
- Serial number as shown on the rating label.

UK Helpline 0844 871 0949

Replacement Parts 0844 873 0715

Ireland Helpline 1800 409 119

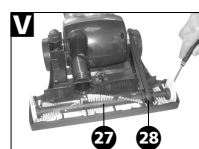
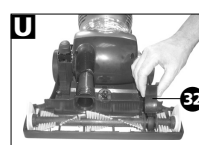
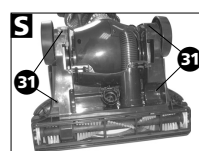
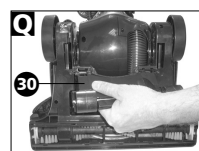
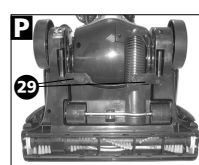
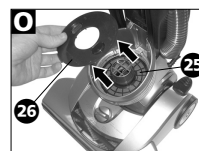

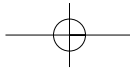

YOUR TWO YEAR GUARANTEE

It is important to retain the retailer's receipt as proof of purchase. Staple your receipt to this back cover for future reference.

Please quote the following information if the product develops a fault. These numbers can be found on the base of the product.

Model no.

Serial no.

All Morphy Richards products are individually tested before leaving the factory. In the unlikely event of any appliance proving to be faulty within 28 days of purchase, it should be returned to the place of purchase for it to be replaced.

If the fault develops after 28 days and within 24 months of original purchase, you should contact the helpline number quoting model number and serial number on the product, or write to Morphy Richards at the address shown. You will be asked to return the product (in secure, adequate packaging) along with a copy of proof of purchase.

Subject to the exclusions set out below (see Exclusions), the faulty appliance will then be repaired or replaced and dispatched usually within seven working days of receipt.

If, for any reason, this item is replaced during the 2-year guarantee period, the guarantee on the new item will be calculated from original purchase date. Therefore, it is vital to retain your original receipt or invoice to indicate the date of initial purchase.

To qualify for the two-year guarantee, the appliance must have been used according to the manufacturer's instructions. For example, the filters must have been regularly cleaned as instructed.

Morphy Richards shall not be liable to replace or repair the goods under the terms of the Guarantee where:

- 5 The appliance is second hand.
 - 6 Morphy Richards are not liable to carry out any type of servicing work under the guarantee.
 - 7 Consumables such as the filters and belt are not covered by the guarantee.
- This guarantee does not confer any rights other than those expressly set out above and does not cover any claims for consequential loss or damage. This guarantee is offered as an additional benefit and does not affect your statutory rights as a consumer.
 - This guarantee is valid in the UK and Ireland only.

EXCLUSIONS

- 1 The fault has been caused or is attributable to accidental use, mis-use, negligent use or used contrary to the manufacturer's recommendations or where the fault has been caused by power surges or damage caused in transit.
- 2 The appliance has been used on a voltage supply other than that stamped on the products.
- 3 Repairs have been attempted by persons other than our service staff (or authorised dealer).
- 4 The appliance has been used for hire purposes or non-domestic use.



For electrical products sold within the European Community. At the end of the electrical products useful life it should not be disposed of with household waste. Please recycle where facilities exist. Check with your Local Authority or retailer for recycling advice in your country.

morphy richards®

**The After Sales Division
Morphy Richards Ltd**
Mexborough, South Yorkshire,
England, S64 8AJ

Helplines (office hours)
UK 0844 871 0949
Spare Parts 0844 873 0715
Republic of Ireland 1800 409 119

Morphy Richards products are intended for household use only.

Morphy Richards has a policy of continuous improvement in product quality and design. The company therefore reserves the right to change the specification of its models at any time.

VC73281 MUK Rev 1 03/08

For details of other products in the Morphy Richards range, please see our website . . .

www.morphyrichards.com

8

